

PROPRIETARY NOTICE:
 THIS DOCUMENT AND THE ACCOMPANYING DATA ARE NOT TO BE
 REPRODUCED, USED BY OR DISCLOSED TO ANYONE, BUT THE
 CUSTOMER OF SAID DEVICE, IN WHOLE OR IN PART WITHOUT THE
 EXPRESS CONSENT OF INFRARED ASSOCIATES, INC.

REVISIONS

ZONE	REV	DESCRIPTION	DATE	APPROVED
	0	INITIAL RELEASE	4/22/2014	

FUNCTION	PIN
N/C	1
N/C	2
DETECTOR	3
THERMISTER	4
THERMISTER	5
DETECTOR	6

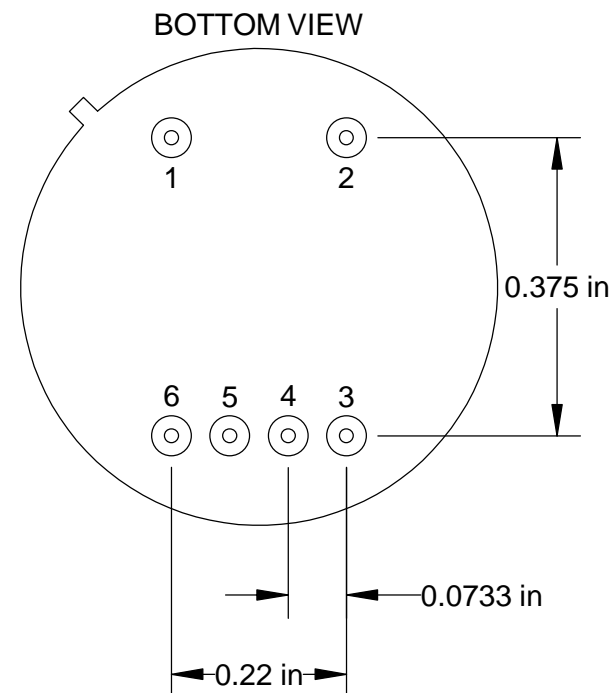
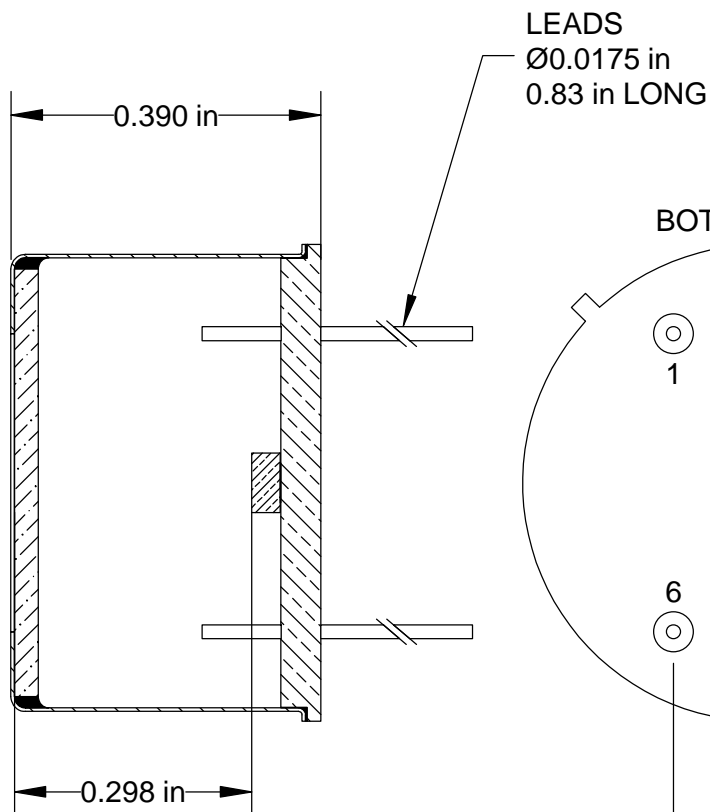
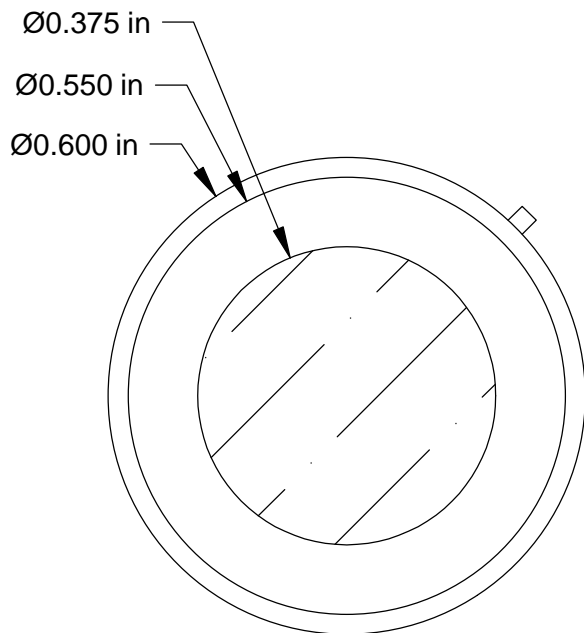

DIMENSIONS UNLESS OTHERWISE SPECIFIED
 ARE IN INCHES.
 TOLERANCES:
 FRACTIONS +/- 1/64, ANGLES +/- 0.5 DEGREES
 3 PLACE DECIMALS +/- 0.005
 2 PLACE DECIMALS +/- 0.01

DO NOT SCALE

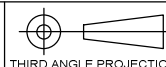

InfraRed Associates, Inc.
 Stuart, Florida 34997

MATERIAL

PREPARED	B. THORP
CHECKED	F. ROTHE
ENGINEERING	
PRODUCTION	
QUALITY	

TO-8
Room Temperature Detector

FINISH

SCALE:	SHEET 1 OF 1
JOB NO.	NEXT ASSY.

SIZE
A

FSCM NO.

DRAWING NO.

1800-0253

REV.

-